

## High Current Low Dropout Regulators

### General Description

The MIC29502WT/WU is a high current, high accuracy and low-dropout voltage regulator. The 5A LDO regulator features 560 mV (full load) dropout voltage and very low ground current. Designed for high-current loads, these devices also find applications in lower current, low-dropout critical systems, where their dropout voltages and ground current values are important attributes. Along with a total accuracy of  $\pm 2\%$  (over temperature, line, and load regulation) the regulator features very fast transient recovery from input voltage surges and output load current changes. The MIC29502WT/WU has an adjustable output that can be set by two external resistors to a voltage between 1.24V and 15V. In addition, the device is fully protected against over current faults, reversed input polarity, reversed lead insertion, and over temperature operation. A TTL/CMOS logic enable (EN) pin is available in the MIC29502WT/WU to shutdown the regulator. When not used, the device can be set to continuous operation by connecting EN to the input (IN).

The MIC29502WT is available in TO220-5 package.

The MIC29502WU is available in TO263-5 package

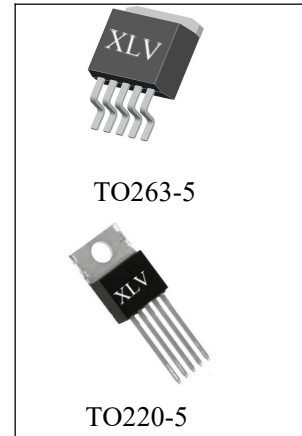

### Features

- High Current Capability
- Low-Dropout Voltage
- Low Ground Current
- Accurate 1% Guaranteed Tolerance
- Fast Transient Response
- Operating Input Voltage Range: 3V to 26V
- 1.24V to 15V Adjustable Output Voltage
- Zero-Current Shutdown Mode
- Adjustable Version

### Applications

- Processor Peripheral and I/O Supplies
- High-Efficiency “Green” Computer Systems
- Automotive Electronics
- High-Efficiency Linear Low Power Supplies
- Battery Powered Equipment
- PC Add-In Cards
- High-Efficiency Post-Regulator for Switching Supply

## Functional Block Diagram

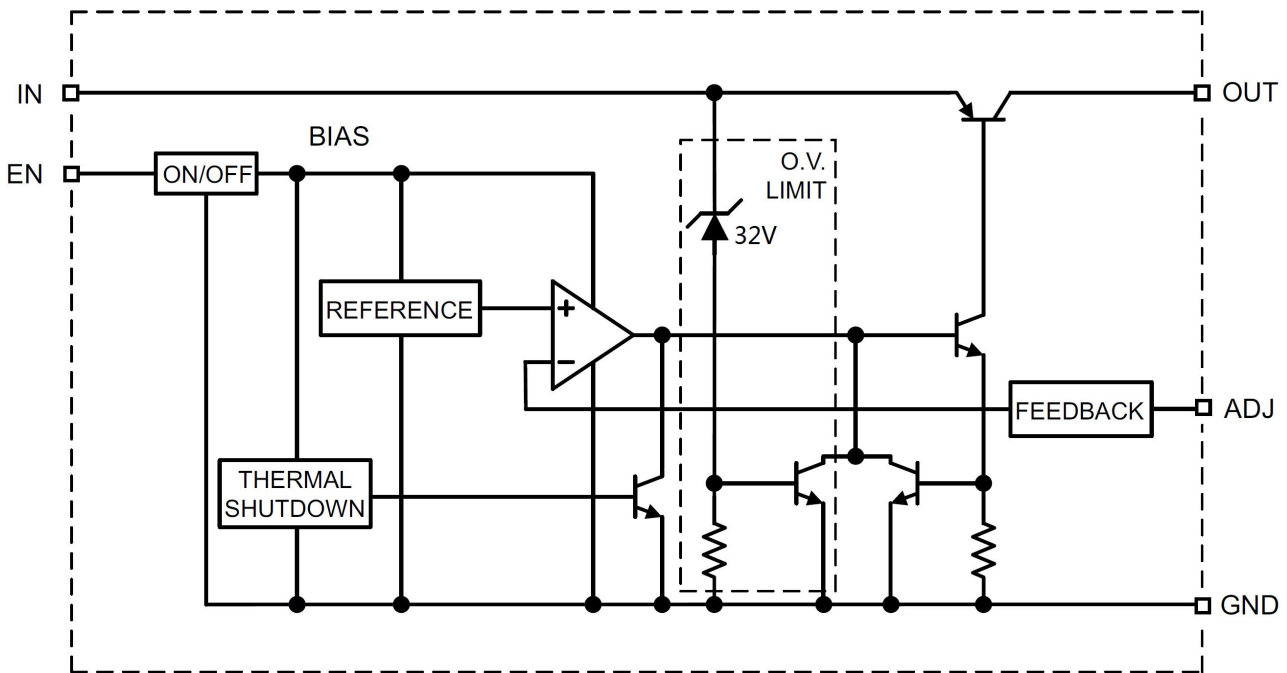

## Pin Configuration

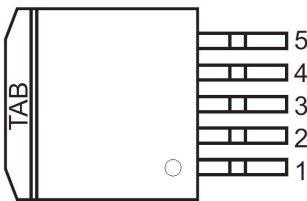

MIC29502WU(TO263-5)

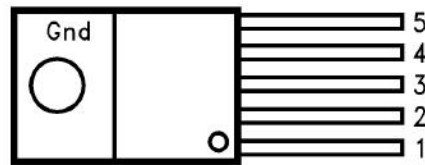

MIC29502WT(TO220-5)

## Pin Description

Pin Number	Pin Name	Function Description
1	EN	Enable pin, Active high TTL/CMOS compatible control input. Logic-high=enable, Logic-low=shutdown. Do not float.
2	V <sub>IN</sub>	Supplies the current to the output power device.
3, TAB	GND	Ground TAB is also connected internally to the IC's ground on both Packages.
4	V <sub>OUT</sub>	The regulator output voltage.
5	ADJ	Adjustable regulator feedback input that connects to the resistor voltage divider that is placed from V <sub>OUT</sub> to GND in order to set the output voltage.

## Absolute Maximum Ratings

Parameter Name	Symbol	Value	Unit
Power Dissipation	P <sub>D</sub>	Internally Limited	
Input Supply Voltage (Note1)	V <sub>IN</sub>	-20~+50	V
Enable Input Voltage	V <sub>EN</sub>	-0.3V~V <sub>IN</sub>	V
Operating Junction Temperature	T <sub>J</sub>	-40~+125	°C
Lead Temperature (soldering, 5 seconds)	T <sub>LEAD</sub>	260	°C
Storage Temperature Range	T <sub>STG</sub>	-55~+150	°C
Thermal Resistance(JC)	θ <sub>JC</sub>	3	°C/W
Thermal Resistance(JA)	θ <sub>JA</sub>	28	°C/W

Notice: The maximum allowable power dissipation is a function of ambient temperature, the maximum allowable junction temperature and the thermal resistance from junction to air (i.e., T<sub>A</sub>, T<sub>J</sub>, θ<sub>JA</sub>). Exceeding the maximum allowable power dissipation will cause the device operating junction temperature to exceed the maximum +125°C rating. Sustained junction temperatures above +125°C can impact the device reliability.

Note1: Maximum positive supply voltage of 50V must be of limited duration(<100ms) and duty cycle(<1%).The maximum continuous supply voltage is 26V. Exceeding the absolute maximum rating may damage the device.

## Recommended Operating Conditions

Parameter Name	Symbol	Value	Unit
Operating Input Voltage	V <sub>IN</sub>	+3~+26	V

## Electrical Characteristics

All measurements at  $T_J = 25^\circ\text{C}$  unless otherwise noted.  $V_{IN} = V_{OUT} + 1\text{V}$ ,  $I_{OUT} = 100\text{mA}$ ,

**Bold** values indicate  $-40^\circ\text{C} \leq T_J \leq +125^\circ\text{C}$ .

Parameter Name	Symbol	Test Conditions	Min.	Typ.	Max.	Units	
<b>Output Voltage</b>							
Output Voltage Accuracy	$\Delta V_{OUT}$	$100\text{mA} \leq I_{OUT} \leq 5\text{A}$ , $(V_{OUT} + 1\text{V}) \leq V_{IN} \leq 26\text{V}$	-2		2	%	
Line Regulation	$\frac{\Delta V_{OUT}}{\Delta V_{IN}}$	$I_O = 100\text{mA}$ , $(V_{OUT} + 1\text{V}) \leq V_{IN} \leq 26\text{V}$		0.1	0.5	%	
Load Regulation	$\frac{\Delta V_{OUT}}{\Delta I_{OUT}}$	$V_{IN} = V_{OUT} + 1\text{V}$ , $100\text{mA} \leq I_{OUT} \leq 5\text{A}$		0.2	1	%	
Dropout Voltage	$V_{DO}$	$I_O = 100\text{mA}$	$\Delta V_{OUT} = -1\%$ (*1)		100	200	mV
		$I_O = 750\text{mA}$			220		
		$I_O = 2.5\text{A}$			300		
		$I_O = 5\text{A}$			560	800	
<b>Ground Current</b>							
Ground Current	$I_{GND}$	$I_O = 750\text{mA}$	$V_{IN} = V_{OUT} + 1\text{V}$ (*2)		5	20	mA
		$I_O = 2.5\text{A}$			15		
		$I_O = 5\text{A}$			60	150	
Ground Pin Current at Dropout	$I_{GND\_DO}$	$V_{IN} = 0.5\text{V}$ less than specified $V_{OUT}$ , $I_{OUT} = 10\text{mA}$		2		mA	
Current Limit	$I_{LIMIT}$	$V_{OUT} = 0\text{V}$ (*3)	5	7		A	
Output Noise Voltage (10Hz to 100kHz) $I_L = 100\text{mA}$	$e_N$	$C_L = 10\mu\text{F}$		400		$\mu\text{V}(\text{rms})$	
		$C_L = 33\mu\text{F}$		260			
Ground Pin Current in Shutdown	$I_{SHDN}$	$V_{IN} = 26\text{V}$		32		$\mu\text{A}$	
<b>Reference</b>							
Reference Voltage	$V_{REF}$	(*4)	1.215		1.267	V	
Adjust Pin Bias Current	$I_{ADJ}$			40	80	nA	
					120		
<b>Enable Input</b>							
Input Logic Voltage	$V_{ENABLE}$	Low (OFF)			0.8	V	
		High (ON)	2.4				
Enable Pin Input Current	$I_{EABLE}$	$V_{EN} = 4.2\text{V}$			15	30	$\mu\text{A}$
						75	
		$V_{EN} = 0.8\text{V}$				2	$\mu\text{A}$
						4	
Regulator Output Current in Shutdown	$I_{OUT\_SHDN}$	(*5)		10		$\mu\text{A}$	
					20		

\* 1: Dropout voltage is defined as the input-to-output differential when the output voltage drops to 99% of its nominal value with  $V_{OUT} + 1\text{V}$  applied to  $V_{IN}$ .

\* 2: Ground pin current is the regulator quiescent current. The total current drawn from the source is the sum of the load current plus the ground pin current.

\* 3:  $V_{IN} = V_{OUT}(\text{nominal}) + 1\text{V}$ . For example, use  $V_{IN} = 4.3\text{V}$  for a 3.3V regulator or use 6V for a 5V regulator. Employ

pulse-testing procedures to minimize temperature rise.

\* 4:  $V_{REF} \leq V_{OUT} \leq (V_{IN} - 1\text{ V})$ ,  $3\text{ V} \leq V_{IN} \leq 26\text{ V}$ ,  $10\text{ mA} < I_L \leq I_{FL}$ ,  $T_J \leq T_J(\text{MAX})$ .

\* 5:  $V_{EN} \leq 0.8\text{ V}$ ,  $V_{IN} \leq 26\text{ V}$  and  $V_{OUT} = 0$ .

## Typical Application

Below is adjustable output voltage configuration. For best results, the total series resistance should be small enough to pass the minimum regulator load current.

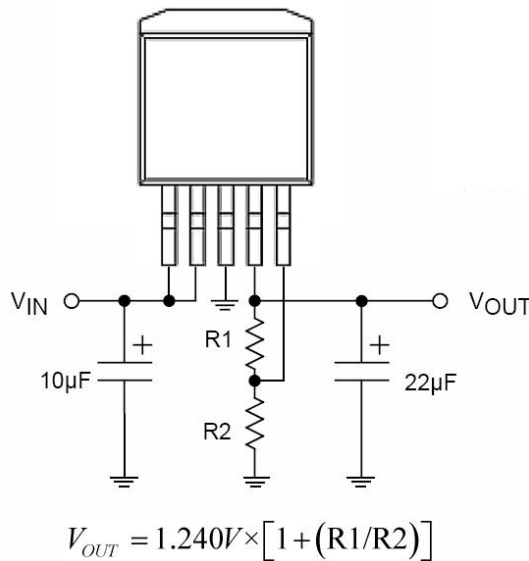

## Application Information

The MIC29502WT/WU is a high performance low-dropout voltage adjustable regulator suitable for all moderate to high-current voltage regulator application. Its 560mV typical dropout voltage at full load makes it especially valuable in battery-powered systems and as high efficiency noise filters in post-regulator applications. Unlike older NPN-pass transistor designs, where the minimum dropout voltage is limited by the base-emitter voltage drop and collector-emitter saturation voltage, dropout performance of the PNP output of this device is limited merely

by the low  $V_{CE}$  saturation voltage.

A trade-off for the low dropout voltage is a varying base drive requirement. The MIC29502WT/WU is fully protected from damage due to fault conditions. Current limiting is provided. This limiting is linear; output current under over-load conditions is constant. Thermal shutdown disables the device when the die temperature exceeds the 125°C maximum safe operating temperature. The output structure of this regulator allows voltages in excess of the desired output voltage to be applied without reverse current flow. MIC29502WT/WU offers a logic level ON/OFF control: when disabled, the device draws 32µA at maximum 26V input.

## Capacitor Requirements

For stability and minimum output noise, a capacitor on the regulator output is necessary. The value of this capacitor is dependent upon the output current; lower currents allow smaller capacitors. MIC29502WT/WU regulator is stable with the following minimum capacitor values at full load: 10µF. This capacitor need not be an expensive low ESR type: aluminum electrolytics are adequate. In fact, extremely low ESR capacitors may contribute to instability. Tantalum capacitors are recommended for systems where fast load transient response is important.

Where the regulator is powered from a source with a high AC impedance, a 0.1µF capacitor connected between Input and GND is recommended.

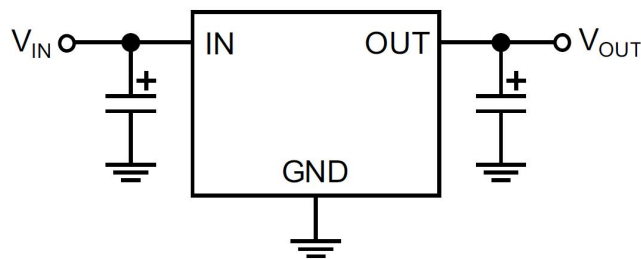

Fig. Linear Regulators Require Only Two Capacitors for Operation

## Minimum Load Current

The MIC29502WT/WU regulator operates within a specified loads. If the output current is too small, leakage currents dominate and the output voltage rises. A minimum load current of 10 mA is necessary for proper regulation and to swamp any expected leakage current across the operating temperature range.

For best performance the total resistance ( $R_1+R_2$ ) should be small enough to pass the minimum regulator load current of 10 mA.

## Adjustable Regulator Design

The output voltage can be programmed anywhere between 1.25V and the 15V. Two resistors are used. The resistor values are calculated by:

$$R_1 = R_2 \left( \frac{V_{OUT}}{1.240} - 1 \right)$$

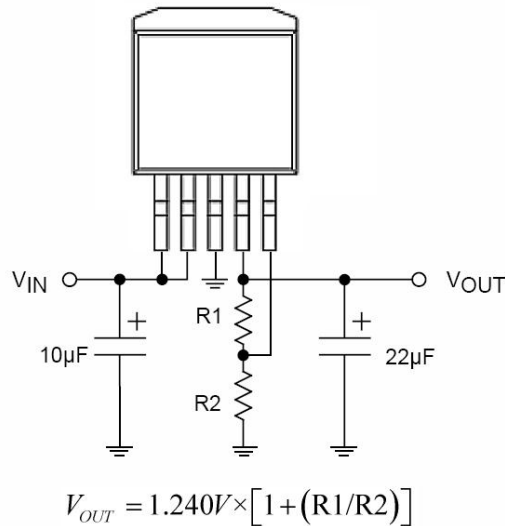

Fig. Adjustable Regulator with Resistors

Where  $V_{OUT}$  is the desired output voltage. Figure shows component definition. Applications with widely varying load currents may scale the resistors to draw the minimum load current required for proper operation.

### Enable Input

MIC29502WT/WU features an enable (EN) input that allows ON/OFF control of the device. The EN input has TTL/CMOS compatible thresholds for simple interfacing with logic, or may be directly tied to  $V_{IN}$ . Enabling the regulator requires approximately 20µA of current into the EN pin.

### Transient Response and 5V to 3.3V Conversion

The MIC29502WT/WU has excellent response to variations in input voltage and load current. By virtue of its low dropout voltage, the device does not saturate into dropout as readily as similar NPN-based designs. A 3.3V output LDO will maintain full speed and performance with an input supply as low as 4.2V, and will still provide some regulation with supplies down to 3.8V, unlike NPN devices that require 5.1V or more for good performance and become nothing more than a resistor under 4.6V of input. MIC29502WT/WU PNP regulators provide superior performance in “5V to 3.3V” conversion applications than NPN regulators, especially when all tolerances are considered.

### Thermal Design

Linear regulators are simple to use. The most complicated design parameters to consider are thermal characteristics. Thermal design requires the following application-specific parameters:

- Maximum ambient temperature,  $T_A$
- Output Current,  $I_{OUT}$
- Output Voltage,  $V_{OUT}$
- Input Voltage,  $V_{IN}$

First, calculate the power dissipation of the regulator from these numbers and the device parameters from this datasheet.

$$P_D = I_{OUT}(1.05V_{IN} - V_{OUT})$$

Where the ground current is approximated by 5% of  $I_{OUT}$ . Then the heat sink thermal resistance is determined with this formula:

$$\theta_{SA} = \frac{T_{JMAX} - T_A}{P_D} - (\theta_{JC} + \theta_{CS})$$

Where  $T_{J(MAX)} \leq 125^\circ\text{C}$  and  $\theta_{CS}$  is between  $0^\circ\text{C/W}$  and  $2^\circ\text{C/W}$ .

The heat sink may be significantly reduced in applications where the minimum input voltage is known and is large compared with the dropout voltage. Use a series input resistor to drop excessive voltage and distribute the heat between this resistor and the regulator. The low dropout properties of regulators allow very significant reductions in regulator power dissipation and the associated heat sink without compromising performance. When this technique is employed, a capacitor of at least  $0.1\mu\text{F}$  is needed directly between the input and regulator ground.

## Outline Dimensions

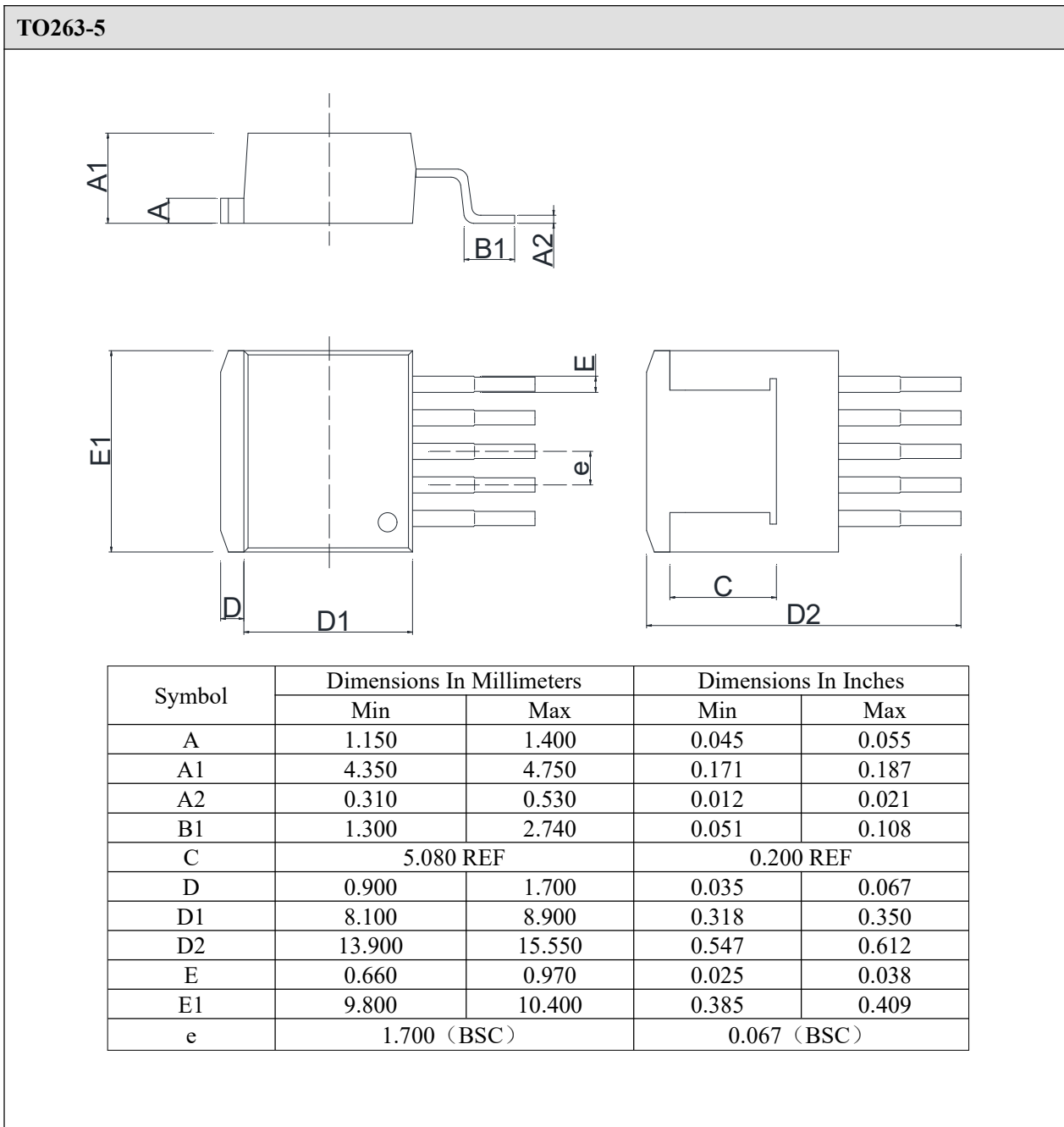

**TO220-5**

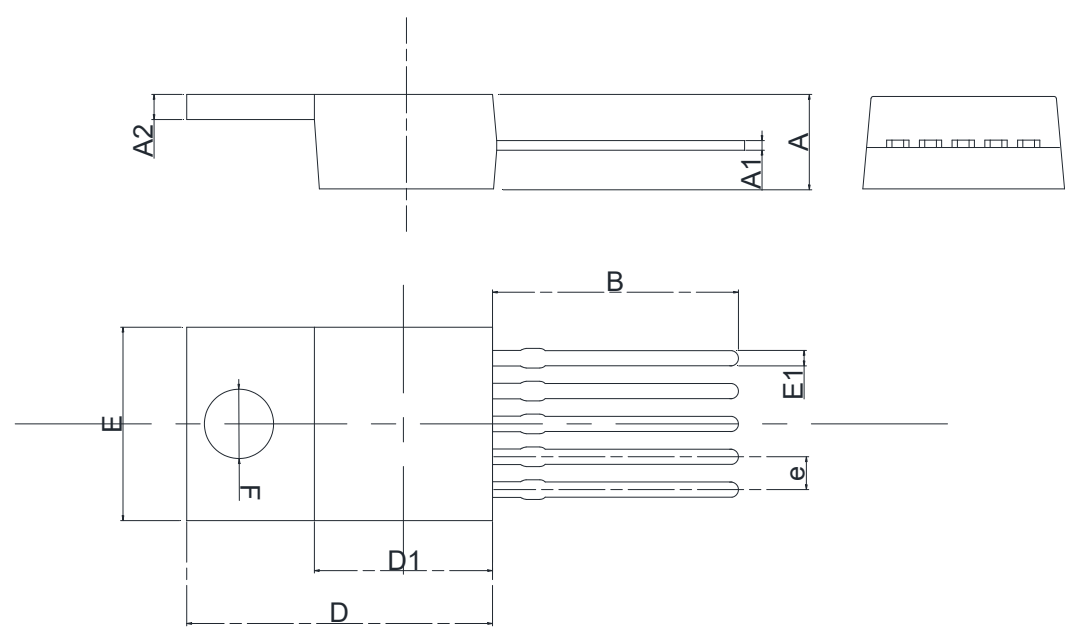

Symbol	Dimensions In Millimeters		Dimensions In Inches	
	Min	Max	Min	Max
A	4.300	4.700	0.169	0.185
A1	0.450	0.600	0.017	0.023
A2	1.250	1.400	0.049	0.055
B	12.880	13.380	0.507	0.527
D	15.500	15.900	0.610	0.626
D1	9.000	9.400	0.354	0.370
E	9.700	10.100	0.381	0.398
E1	0.660	0.914	0.025	0.036
e	1.702 (BSC)		0.670 (BSC)	
F	Φ 3.500	Φ 3.700	Φ 0.137	Φ 0.146

- ❖ XLV reserves the right to modify any products or specifications described in this document at any time without prior notice. Customers must confirm that the specification documentation obtained is the latest version and verify the completeness and accuracy of all information before placing orders.
- ❖ Any semiconductor product may fail or malfunction under specific conditions. When using XLV products for system design and machine manufacturing, customers must strictly comply with applicable safety standards and adopt all necessary safeguards to mitigate potential failure risks, thereby preventing personal injury or property damage.
- ❖ XLV will continuously pursue optimization of product performance and quality, striving to provide customers with superior integrated circuit solutions.